

A
B
C
D
E

SECTION **PB**

PARKING BRAKE SYSTEM

CONTENTS

<p>PRECAUTIONS 2</p> <p> Precautions for Supplemental Restraint System (SRS) "AIR BAG" and "SEAT BELT PRE-TENSIONER" 2</p> <p>PARKING BRAKE SYSTEM 3</p> <p> On-Vehicle Service (Foot Lever Type) 3</p> <p> INSPECTION 3</p> <p> ADJUSTMENT 3</p> <p> On-Vehicle Service (Hand Lever Type) 4</p> <p> INSPECTION 4</p> <p> ADJUSTMENT 4</p> <p>PARKING BRAKE CONTROL 5</p> <p> Components 5</p> <p> Removal and Installation 6</p>	<p> REMOVAL 6</p> <p> INSTALLATION 6</p> <p> Inspection 6</p> <p>PARKING BRAKE SHOE 7</p> <p> Components 7</p> <p> Removal and Installation 7</p> <p> REMOVAL 7</p> <p> INSPECTION AFTER REMOVAL 8</p> <p> INSTALLATION 8</p> <p> BREAKING IN DRUM AND LINING 9</p> <p>SERVICE DATA AND SPECIFICATIONS (SDS) 10</p> <p> Parking Drum Brake 10</p> <p> Parking Brake Control 10</p>
---	---

PB

G

H

I

J

K

L

M

PRECAUTIONS

PRECAUTIONS

PF0:00001

Precautions for Supplemental Restraint System (SRS) “AIR BAG” and “SEAT BELT PRE-TENSIONER”

AFS0021T

The Supplemental Restraint System such as “AIR BAG” and “SEAT BELT PRE-TENSIONER”, used along with a front seat belt, helps to reduce the risk or severity of injury to the driver and front passenger for certain types of collision. This system includes seat belt switch inputs and dual stage front air bag modules. The SRS system uses the seat belt switches to determine the front air bag deployment, and may only deploy one front air bag, depending on the severity of a collision and whether the front occupants are belted or unbelted. Information necessary to service the system safely is included in the SRS and SB section of this Service Manual.

WARNING:

- To avoid rendering the SRS inoperative, which could increase the risk of personal injury or death in the event of a collision which would result in air bag inflation, all maintenance must be performed by an authorized NISSAN/INFINITI dealer.
- Improper maintenance, including incorrect removal and installation of the SRS, can lead to personal injury caused by unintentional activation of the system. For removal of Spiral Cable and Air Bag Module, see the SRS section.
- Do not use electrical test equipment on any circuit related to the SRS unless instructed to in this Service Manual. SRS wiring harnesses can be identified by yellow and/or orange harnesses or harness connectors.

PARKING BRAKE SYSTEM

PARKING BRAKE SYSTEM

PFP:36010

On-Vehicle Service (Foot Lever Type) INSPECTION

AFS0021L

- While depressing parking brake pedal to specified amount of force. Check that the pedal stroke is within the range of the specified stroke amount.

Number of notches : 3 - 4

- Check that warning lamp comes on when parking brake pedal is depressed with in one notch.

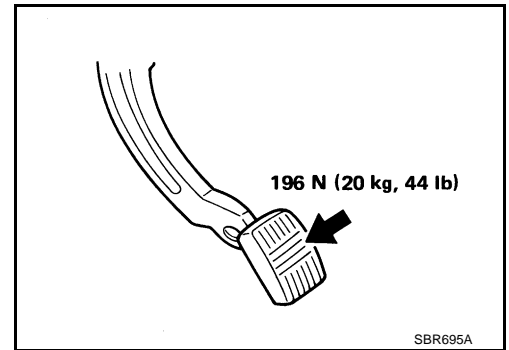

ADJUSTMENT

- To perform adjustment operations, remove tire from vehicle with power tool. Using a wheel nut, fix disc to hub preventing it from tilting.

1. Insert a deep-well socket wrench to rotate self-locking nut to loosen cable sufficiently. Then, after returning pedal completely, adjust the clearance of rear shoes.
2. Remove tire from vehicle.

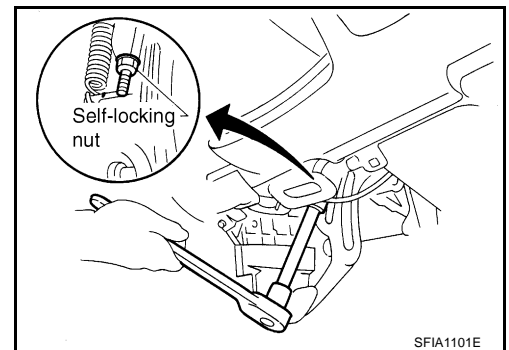

3. Remove adjuster hole plug installed on the disc rotor. Using a flat-bladed screwdriver, turn adjuster to clock wise as shown in the figure until adjuster is locked. After locking, turn adjuster to the opposite direction by 5 or 6 notches.
4. Rotate disc rotor to make sure that there is no drag. Then install adjuster hole plug.
5. After adjusting the clearance of rear shoes, with no drag on the rear brake, adjust cable as follows:
 - a. Operate pedal 10 or more times with the force of 294 N (30 kg, 66 lb).
 - b. Depress pedal until a deep-well socket can be inserted. Insert the deep-well socket, and rotate self-locking nut to adjust the pedal stroke.

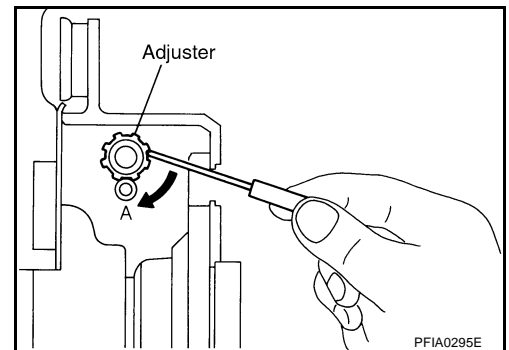

CAUTION:

Do not reuse self-locking nut after removing it.

- c. After operating pedal 3 to 4 times with the force of 196 N (20 kg, 44 lb), make sure that the pedal stroke is within the specified value.
- d. With pedal completely returned, make sure that there is no drag on the rear brake.

PARKING BRAKE SYSTEM

AFS0021M

On-Vehicle Service (Hand Lever Type) INSPECTION

- While operating parking brake lever to specified amount of force. Check that the lever stroke is within the range of the specified stroke amount.

Number of notches : 6 - 7

- Check that warning lamp comes on when parking brake lever is operated with in one notch.

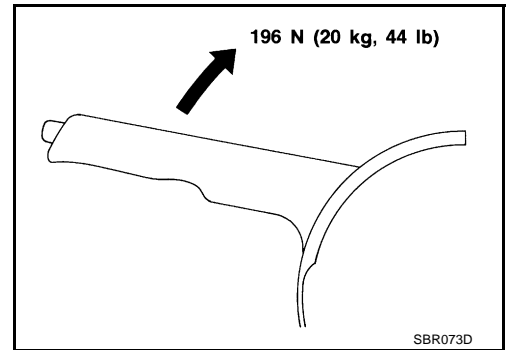

ADJUSTMENT

- To perform adjustment operations, remove tire from vehicle with power tool. Using a wheel nut, fix disc to hub preventing it from tilting.

1. Insert a deep-well socket wrench to rotate self-locking nut to loosen cable sufficiently. Then, after returning the lever completely, adjust the clearance of rear shoes.
2. Remove tire from vehicle.

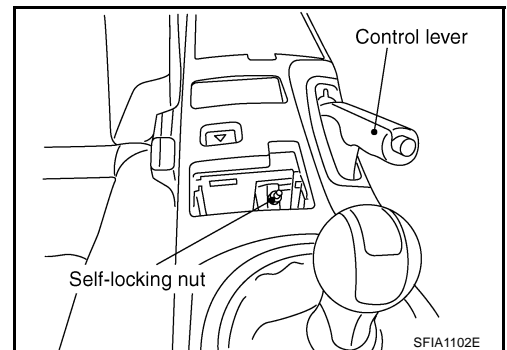

3. Remove adjuster hole plug installed on the disc rotor. Using a flat-bladed screwdriver, turn adjuster to clock wise as shown in the figure until adjuster is locked. After locking, turn adjuster to the opposite direction by 5 or 6 notches.
4. Rotate disc rotor to make sure that there is no drag. Then install adjuster hole plug.
5. After adjusting the clearance of rear shoes, with no drag on the rear brake, adjust cable as follows:

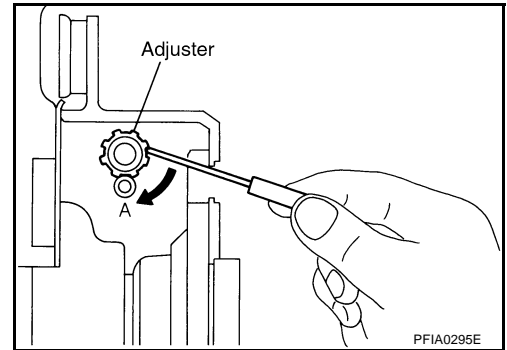

- a. Operate lever 10 or more times with the force of 294 N (30 kg, 66 lb).
- b. Operate lever until a deep-well socket can be inserted. Insert deep-well socket, and rotate self-locking nut to adjust the lever stroke.

CAUTION:

Do not reuse self-locking nut after removing it.

- c. After operating lever 3 to 4 times with the force of 196 N (20 kg, 44 lb), make sure that the lever stroke is within the specified value.
- d. With lever completely returned, make sure that there is no drag on the rear brake.

PARKING BRAKE CONTROL

PPF:36010

AFS0021N

PARKING BRAKE CONTROL

Components

Foot lever type

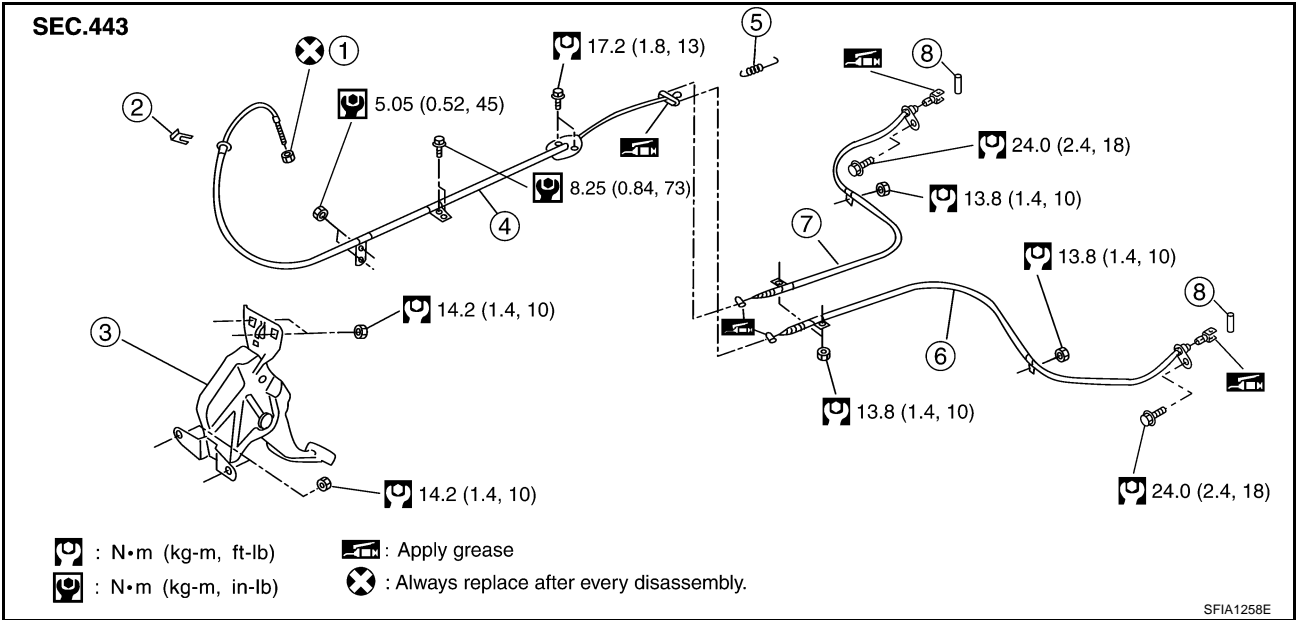

- | | | |
|---------------------|------------------|--------------------|
| 1. Self-locking nut | 2. Lock plate | 3. Device assembly |
| 4. Front cable | 5. Return spring | 6. LH rear cable |
| 7. RH rear cable | 8. Pin | |

Hand lever type

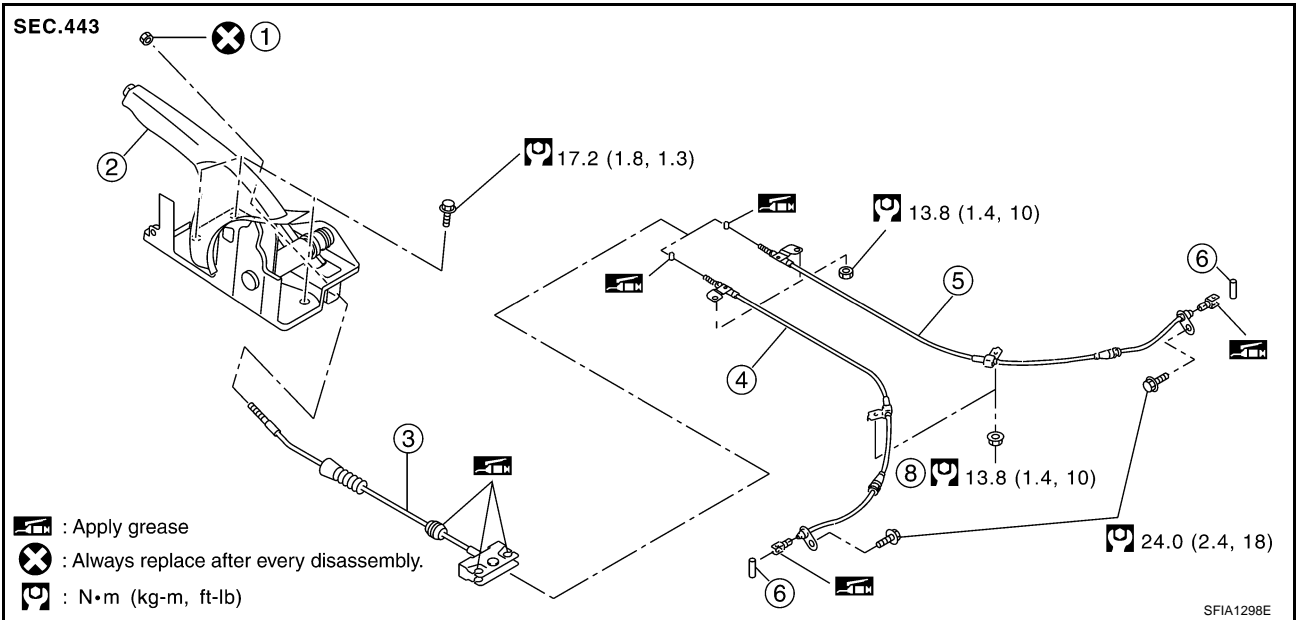

- | | | |
|---------------------|--------------------|----------------|
| 1. Self-locking nut | 2. Device assembly | 3. Front cable |
| 4. LH rear cable | 5. RH rear cable | 6. Pin |

PARKING BRAKE CONTROL

AFS00210

Removal and Installation

REMOVAL

1. Remove instrument lower driver panel (foot lever type). Refer to [IP-16, "Instrument Lower Driver Panel"](#) .
2. Remove center console. Refer to [IP-14, "\(U\) Center Console \(A/T Models\)"](#) , [IP-15, "\(V\) Center Console \(M/T Models\)"](#) .
3. Remove self-locking nut from device assembly.
4. Remove tire from vehicle.
5. Remove rear disc caliper and disc rotor. Refer to [BR-29, "REAR DISC BRAKE"](#) .
6. Remove parking brake shoe, and remove rear cable from toggle lever. Refer to [PB-7, "PARKING BRAKE SHOE"](#) .
7. Remove cable mounting nuts and bolts.
8. Remove right and left rear cable from vehicle.
9. Remove air bag sensor unit with sensor mount bracket. Refer to [SRS-50, "DIAGNOSIS SENSOR UNIT"](#) .
10. Remove front cable mounting nuts and bolts (foot lever type), and remove front cable from vehicle.
11. Remove mounting bolts of device assembly, and remove device assembly from vehicle.

INSTALLATION

1. Install in the reverse order of removal. Tighten mounting bolts and nuts to the specified torque.

CAUTION:

Do not reuse self-locking nut of parking cable.

2. Adjust clearance of parking brake shoes. Refer to [PB-3, "On-Vehicle Service \(Foot Lever Type\)"](#) , [PB-4, "On-Vehicle Service \(Hand Lever Type\)"](#) .

Inspection

AFS00014

- Check device assembly for bend, damage, and cracks. Replace if necessary.
- Check cable for wear and damage.
- Check warning lamp switch. Replace if necessary.
- Check each part for deformation, or damage by contact with other parts. Replace if necessary.

PARKING BRAKE SHOE

PARKING BRAKE SHOE

PFP:44060

Components

AFS0021P

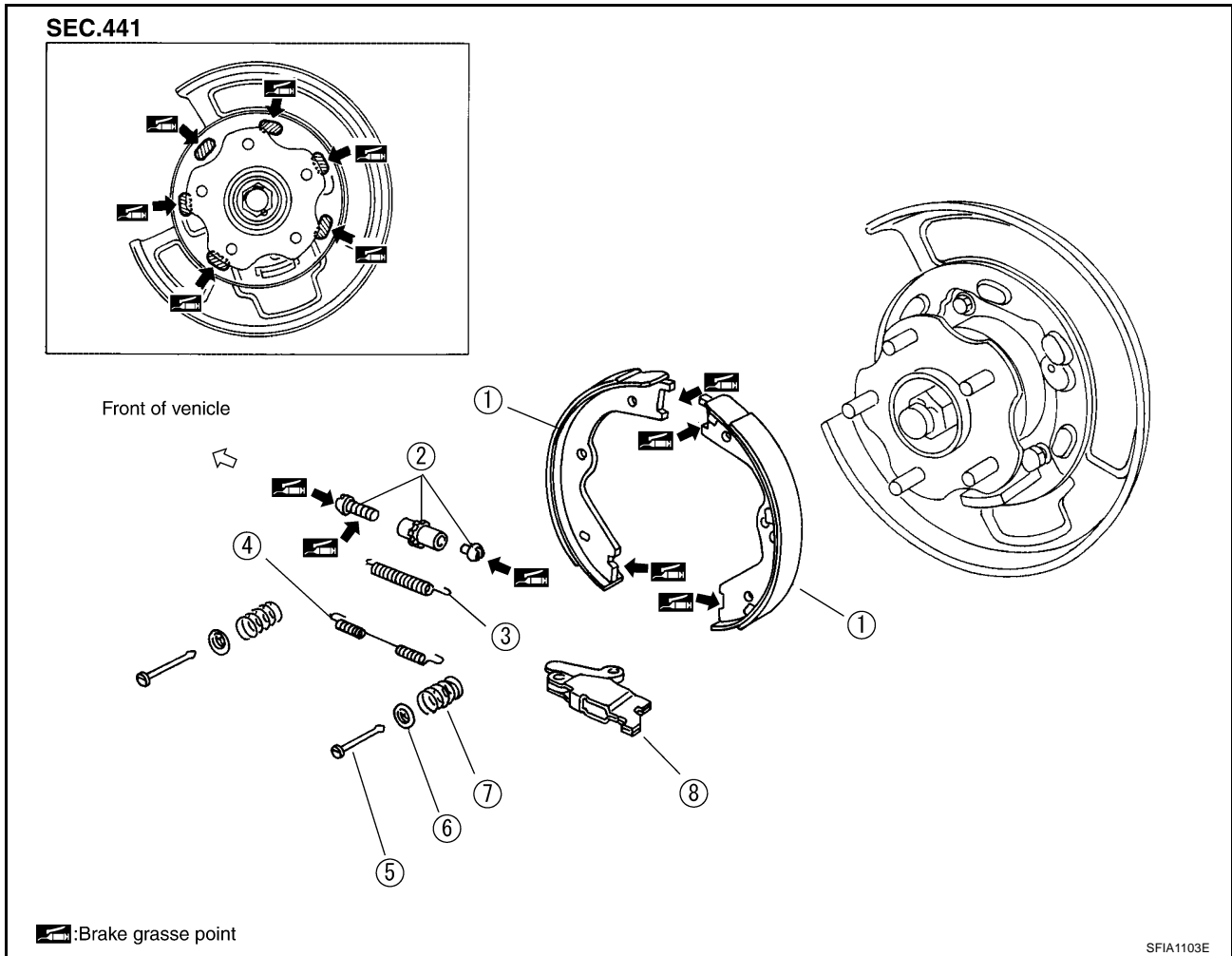

- | | | |
|-----------------------|--------------------|--------------------|
| 1. Shoe | 2. Adjuster | 3. Adjuster spring |
| 4. Return spring | 5. Anti-rattle pin | 6. Retainer |
| 7. Anti-rattle spring | 8. Toggle lever | |

Removal and Installation

REMOVAL

AFS0021Q

CAUTION:

Collect dust on brake parts with dust collector. Do not blow off the dust.

Be careful of the following:

- Remove wheel, and remove disc rotor with parking pedal/lever completely returned.
- If disc rotor cannot be removed, remove as follows.
 1. Fix disc rotor with wheel nut.
 2. Remove adjuster hole plug.
 3. Insert flat-bladed screwdriver through adjuster hole. Turn adjuster to make clearance between brake shoe and drum.

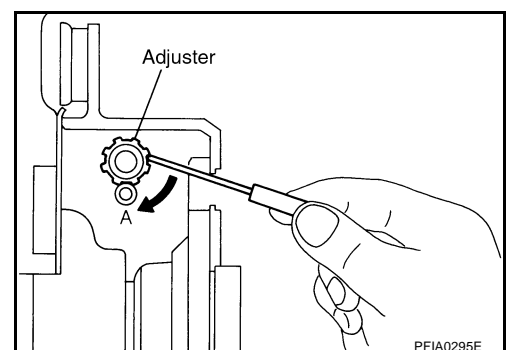

PARKING BRAKE SHOE

INSPECTION AFTER REMOVAL

Lining Thickness Inspection

- Visually check lining for malfunction wear, damage, and peeling.
- Using a scale, check the thickness of lining.

Standard lining thickness : 3.2 mm (0.126 in)
lining wear limit (A) : 1.5 mm (0.059 in)

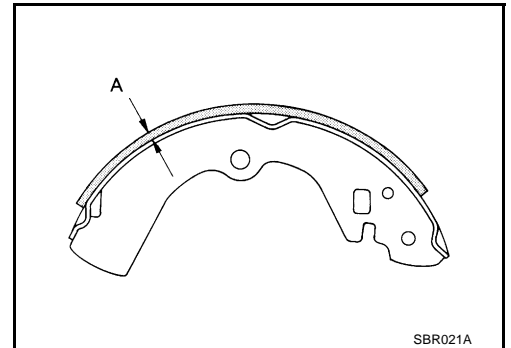

Drum Inner Diameter Inspection

- Check the inner diameter of drum.

Standard inner diameter : 172.0 mm (6.77 in)
Maximum inner diameter : 173.0 mm (6.81 in)

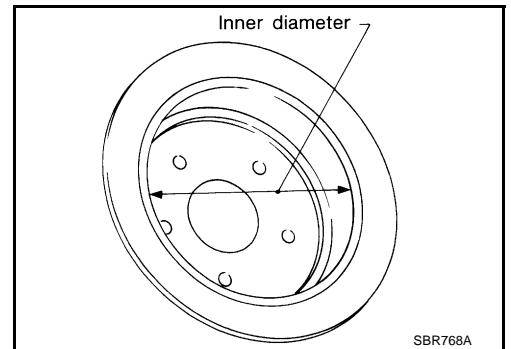

Other Inspections

- Check shoe sliding surface for malfunction wear and damage.
- Check anti-rattle pin for malfunction wear and corrosion.
- Check return spring for sagging.
- Check adjuster for rough operation.
- Visually check the inside of drum for malfunction wear, damage, and cracks. Using a pair of vernier calipers, check the inside of drum.

INSTALLATION

Install all parts in the reverse order of while taking care of the following.

- Apply brake grease to the contact areas shown in the figure.

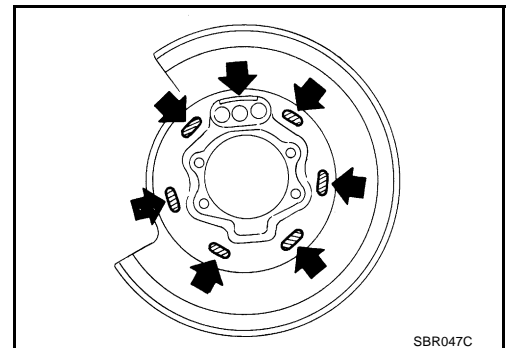

PARKING BRAKE SHOE

- The orientation of adjuster is different from left to right. Assemble adjuster so that the threaded part is expanded when rotating it to the direction shown by the arrow. Contract adjuster to assemble. When disassembling adjuster, apply brake grease to the thread.
- Adjust parking brake pedal or lever stroke to the specified amount.
- After replacing shoe or disc rotor, or if brake does not function well, carry out the break-in operation as follows.

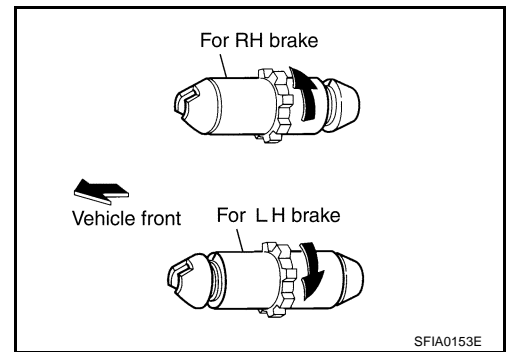

BREAKING IN DRUM AND LINING

CAUTION:

Do not carry out the break-in procedure excessively, because it may cause the uneven wear or premature wear of lining.

When a new rotor/parking brake is installed, or when braking performance is poor, perform the following break-in procedure.

1. Drive the unloaded vehicle on a safe, level and dry road.
2. Depress parking brake pedal or lever with a force of 147 N (15 kg, 33 lb).
3. While depressing the pedal or pulling the lever continue to drive vehicle for-ward 100 m (328 ft) at approximately 35 km/h (22 MPH).
4. Cool down parking brake for approx. Five minutes.
5. After releasing pedal or lever, drive vehicle under the normal conditions for two minutes to cool down parking drum brake.
6. Repeat steps 1 through 5 three times and then repeat only step 5 one more time.
7. After the break-in procedure, check pedal or lever stroke of parking brake. If it is out of the specification, adjust again.

SERVICE DATA AND SPECIFICATIONS (SDS)

SERVICE DATA AND SPECIFICATIONS (SDS)

PFP:00030

Parking Drum Brake

AFS0021R

Type		DS17HF
Brake lining	Standard thickness (new)	3.2 mm (0.126 in)
	Wear limit thickness	1.5 mm (0.059 in)

Parking Brake Control

AFS0021S

Control type	Foot lever / Hand lever
Number of notches (under force of 196 N (20 kg,44lb))	3 - 4 (foot lever type)
	6 - 7 (hand lever type)
Number of notches when warning lamp switch comes on	1